

Installation Instructions:

Ducted

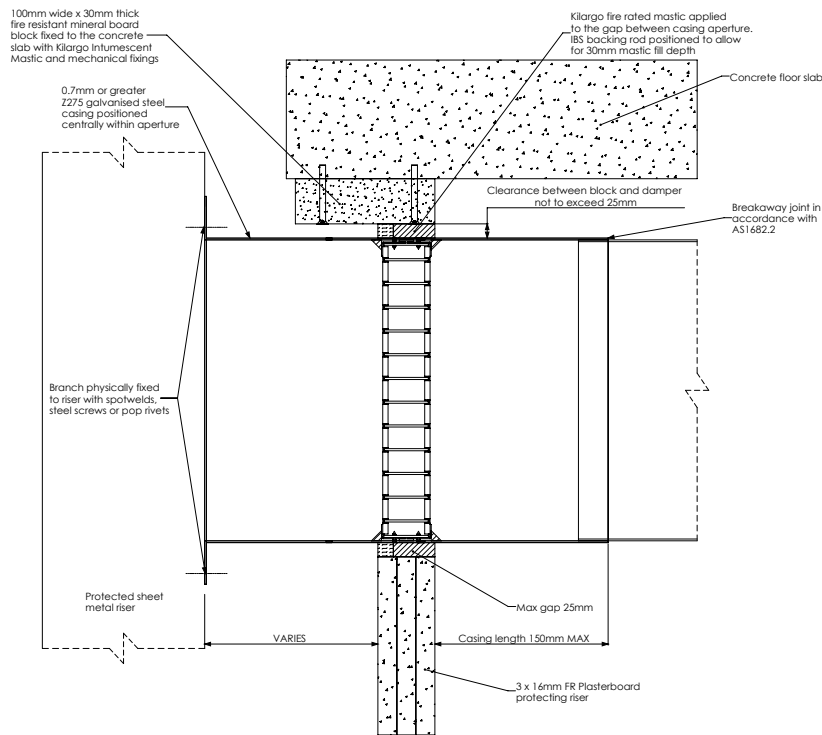

- Step 1** Position and fix damper into ductwork with steel screws or pop rivets as per system drawing ensuring that the damper will be aligned and within the fire separating shaft wall once the duct is attached to the riser.
- Step 2** Seal internal gap between damper and duct with Kilargo Intumescent Mastic as per system drawing.
- Step 3** Measure and cut 100mm wide x 30mm thick fire-resistant mineral board packer (supplied by others) to match the damper width.
- Step 4** Mechanically fix 100mm wide x 30mm thick fire-resistant mineral board packer to concrete slab, with Kilargo Intumescent Mastic in between, and steel anchors as per system drawings.
- Step 5** Mechanically connect duct to riser with steel screws or steel pop rivets.
- Step 6** Once shaftwall has been constructed, firestop gaps between the duct and shaftwall with Kilargo Intumescent Mastic (supplied separately). Ensure fill depth corresponds with those detailed in the system drawing. **Note:** A maximum perimeter clearance of 25mm applies. Use IBS backing rod to control fill depth.
- Step 7** Ensure product and certification labels are in a prominent position for easy identification during subsequent maintenance inspections.
- Step 8** When connecting ductwork to the damper casing, use AS 1682.2 compliant breakaway joint.

System Notes

- Casing, fire-resistant mineral board packer, IBS backing rod & fixings are to be supplied by others.
- Kilargo Intumescent Fire Dampers shall be installed in accordance with this detail, including the use of Kilargo Intumescent Mastic and in accordance with the requirements of AS1682.2.
- Ensure convenient access is provided for visual inspection and cleaning as necessary
- Fire damper insulation requirements are not required for shaft mounted fire damper as per AS 1668.1:2015 cl 3.2.3.1 (a).
- 2mm Minimum gap allowable between damper and aperture. For gaps between 2-5mm, a fillet of Kilargo Intumescent Mastic shall be applied.

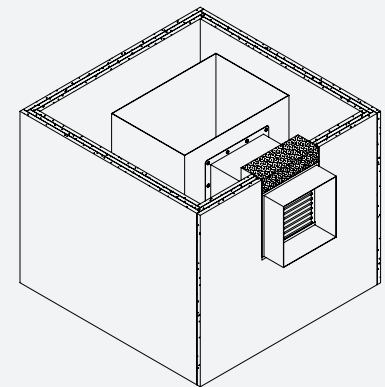

Building element:	Plasterboard 3 x 16
Application:	Mounted in casing - angle free riser connection tight to slab with packer
Maximum size:	300 x 300
FRL	-/120/-
Test reference No.	FAS200229

System No. WSW4