

**Supplied as a complete fire-rated enclosure to ensure compliance.**

### Installation Instructions

1. Mark out the size and location of the damper cut-out. Note: that the cut-out should be 20mm larger than the IFD-CE1 size supplied -for example a 450 x 450mm damper requires a cut out of 470 x 470mm.
2. Prepare hole in ceiling and position damper unit ensuring that perimeter gaps between metal casing and ceiling are even.
3. Attach timber trimmers and tie these back to ceiling joists to fully support weight of system, refer to System Drawing.
4. Attach duct to spigot.
5. From the underside apply Kilargo Intumescent Mastic (supplied separately) and fill (full depth) the gap between casing and ceiling.
6. Fit register / diffuser as required.
7. Ensure convenient access is provided for visual inspection and cleaning as necessary.
8. Ensure product and certification labels are in a prominent position for easy identification during subsequent maintenance routines.

### Notes

1. Product must be fitted in accordance with this detail, including the use of Kilargo Intumescent Mastic to ensure compliance with Kilargo Fire Test Approval detailed.
2. Diffuser, trimmers, angles and fixing screws are to be supplied by others.

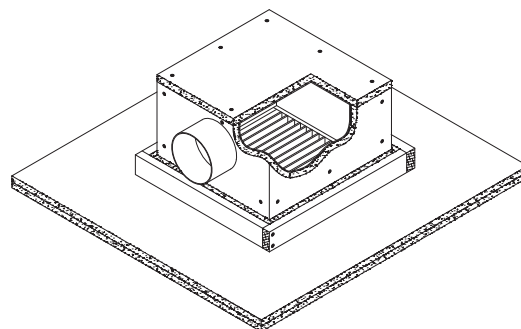

*\* Structural support trimmers not shown for clarity.*

Building Element	FR Plasterboard 2 ply Ceiling
Application	PI/Board clad enclosure (60min RISF Incipient rated)
Maximum Size	600mm x 600mm
FRL	-/60 /60
Test Reference No.	WFRA40904
System No.	<b>CE1</b>