

Installation Instructions

1. Mark out the size and location of the damper cut-out. Note: that the cut-out should be 20mm larger than the Kilargo IFD-CE4 size supplied - for example a 440 x 440mm assembly requires a cut out of 460 x 460mm.
2. Prepare hole in ceiling.
3. Apply Kilargo Intumescent Mastic around the cut out. Position and bed the damper unit in the mastic ensuring that perimeter gaps between metal casing and ceiling are even.
4. Attach timber trimmers and tie these back to ceiling joists to fully support weight of system, refer to system drawing.
5. Attach ductwork to spigot.
6. From the underside apply Kilargo Intumescent Mastic (supplied separately) and fill (full depth) the gap between casing and ceiling.
7. Fit cover / face plate as required.
8. Ensure convenient access is provided for visual inspection and cleaning as necessary.
9. Ensure product and certification labels are in a prominent position for easy identification during subsequent maintenance routines.

Notes

1. Product must be fitted in accordance with this detail, including the use of Kilargo Intumescent Mastic to ensure compliance with Kilargo Fire Test Approval detailed.
2. Trimmers, angles, heat / light / fan unit and fixing screws are to be supplied by others.

NOTE: IFD-CE4 formerly coded as IFD-R04

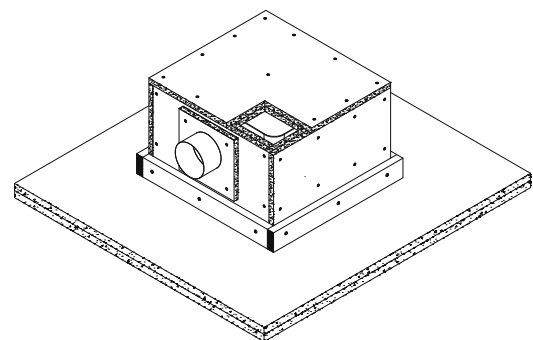

* Structural support trimmers not shown for clarity.

| | |
|--------------------|---|
| Building Element | FR Plasterboard 2 ply Ceiling |
| Application | PI/Board clad 3 way encl. (90min RISF Incipient rated) |
| Maximum Size | 340mm x 340mm or 440mm x 440mm Nominal penetration |
| FRL | -/90/90 |
| Test Reference No. | FP3609 |

System No. **CE4**