

Installation Instructions

Single cell units in steel casing penetrating a concrete floor slab

1. Position damper centrally in floor penetration aperture as per System Drawing.
2. Retain in position as gaps between the damper and floor are filled with Kilargo Intumescent Mastic (supplied separately). Ensure fill depth corresponds with those detailed in the System Drawing.
3. Fasten mounting angles to side of damper casing with steel self drilling screws or steel pop rivets.
4. If connecting ductwork to the installed damper casing ensure that an appropriate ASI682.2 compliant breakaway joint method is used.
5. Ensure product and certification labels are in a prominent position for easy identification during subsequent maintenance inspections.
6. Ensure convenient access is provided for visual inspection and cleaning as necessary.

Notes

1. Product must be fitted in accordance with this detail, including the use of Kilargo Intumescent Mastic to ensure compliance with Kilargo Fire Test Approval detailed.
2. Steel casing, retaining angles & fixing screws are to be supplied by others.

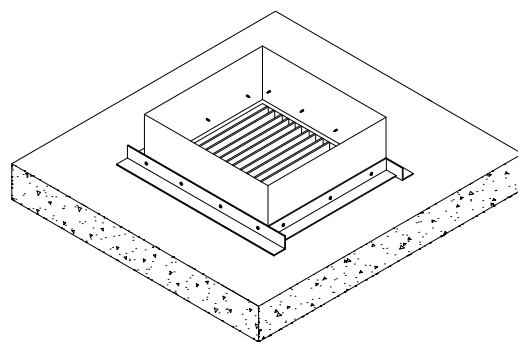

Building Element	Concrete Slab
Application	Mounted in steel casing in penetration
Maximum Size	600mm x 600mm or 0.36m ²
FRL	-/120/120
Test Reference No.	FAS200142

System No. **FL3**