

Installation Instructions

Single cell units surface mounted over masonry wall

1. Fasten mounting angles to sides of damper with steel self drilling screws or steel pop rivets.
2. Position damper centrally over penetration aperture as per system drawing ensuring a minimum of 50mm overlap all around.
3. Liberally apply Kilargo Intumescent Mastic over the surface of the 50mm overlap.
4. Position and bed damper into mastic and fix mounting angles and fix in place using masonry anchors (supplied by others).
5. If necessary re-apply Kilargo Intumescent Mastic (supplied separately) to any gaps between the damper & building element as detailed in the System Drawing.
6. If connecting ductwork to the wall ensure that an appropriate AS1682.2 compliant breakaway joint method is used.
7. Ensure product and certification labels are in a prominent position for easy identification during subsequent maintenance inspections.
8. Ensure convenient access is provided for visual inspection and cleaning as necessary.

Notes

1. Product must be fitted in accordance with this detail, including the use of Kilargo Intumescent Mastic to ensure compliance with Kilargo Fire Test Approval detailed.
2. Fixing screws, brackets and anchors are to be supplied by others.

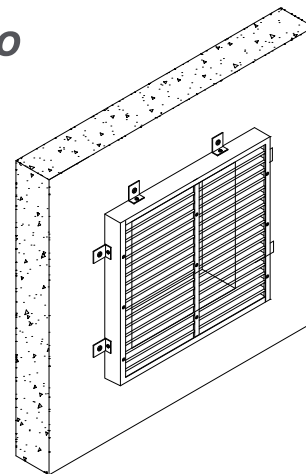

Building Element	Masonry
Application	NO casing - surface mounted over penetration
Maximum Size	600mm x 600mm
FRL	-/120/-
Test Reference No.	FAS200142

System No. **WM4**