

## Installation Instructions

### IFD44 in steel casing penetrating 13mm FR Plasterboard wall

1. Position the damper as detailed in the System Drawing.
2. If applicable, position & fasten mounting angles, using screws & anchors (all supplied by others) as detailed in the System Drawing.
3. Firestop any gaps between the damper & building element with Kilargo Intumescent Mastic (supplied separately). Ensure fill depth corresponds with those detailed in the System Drawing. Note: A maximum perimeter clearance of 25mm applies.
4. If connecting ductwork, ensure that an appropriate ASI682.2 compliant breakaway joint method is used.
5. Ensure convenient access is provided for visual inspection and cleaning as necessary.
6. Ensure product and certification labels are in a prominent position for easy identification during subsequent maintenance inspections.

## Notes

1. Product must be fitted in accordance with this detail, including the use of Kilargo Intumescent Mastic to ensure compliance with Kilargo Fire Test Approval detailed.
2. Steel casing, angles, fixing screws and anchors are to be supplied by others.

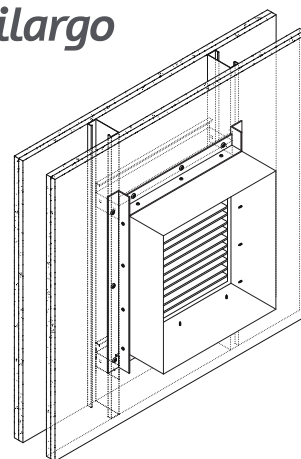

Building Element	13mm FR Plasterboard x 2 layers
Application	Mounted in steel casing in penetration
Maximum Size	2400mm x 2400mm
FRL	-/90/-
Test Reference No.	CSIRO FCO 3378

System No. **WP9**